

OCTAVA™

4x4 HD over Cat 6 Matrix

PRO HD HOME THEATER SERIES

Model: HD44CATMX

Installation Guide

Contents

Application Diagram.....	3
Features.....	3
Matrix Overview.....	4
Infrared Overview.....	5
Zone Receiver (RX) Overview.....	6
Identifying Zone Receiver (RX).....	7
Powering the PoC Zone Receiver.....	8
Powering non-PoC Zone Receiver.....	8
Ethernet cable recommendations.....	9
Ethernet cable installation recommendations.....	9
Installation.....	10
Front Panel Control.....	13
Remote Control Guide.....	13
EDID Switch.....	14
USB Service Port.....	14
EDID Configuration.....	15
Changing EDID mode.....	16
RS232 Controls Commands.....	18
1 RU Rackmount.....	20
Disabling / Enabling IR Remote Receiver.....	20
Warranty.....	21
Disclaimers.....	21
Specifications.....	22

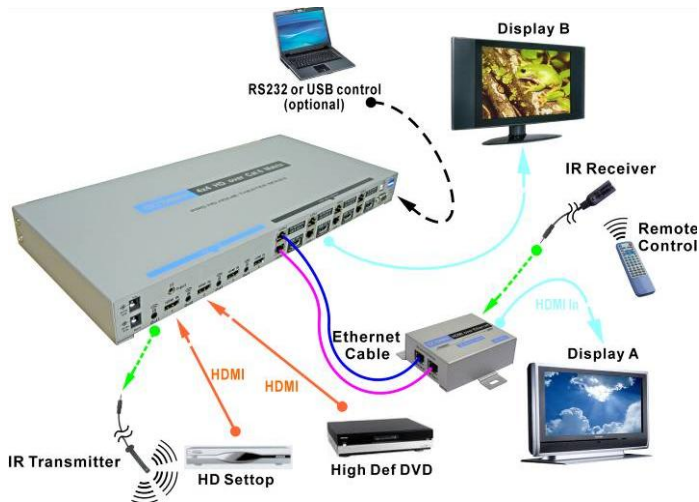

Application Diagram

Features:

- Matrix allows 256 viewing combinations
- View any 4 Source devices simultaneously on up to eight 'mirrored' Display devices.
- Supports 1080p24, 1080p60, 1080p50 plus current consumer 3D formats.
- 4 HDMI inputs
- 4 HDMI OUTPUTS
- 4 Dual RJ-45 Extender Output sockets.
- HDMI and CAT RJ-45 active simultaneously (allows 8 displays)
- Routed IR from remote Zones to control Matrix plus Source devices.
- EDID Management plus custom EDID via USB service port.
- Rack mountable (1 RU) – mounting lugs supplied.
- Discrete IR codes for simple system integration.
- Wired IR port for In-cabinet installations.
- RS232 port for PC or Control System operation.
- Dual Power supply provides PoC (Power over Cable) to connected In-room Receivers via RJ-45 ports.

Matrix Overview:

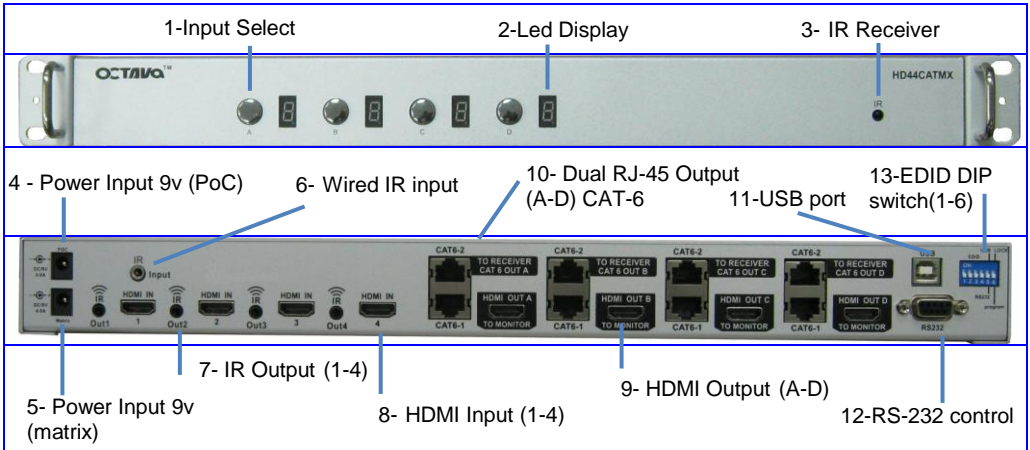

	Item	Description
1	Input Select	Press to select Source device
2	Led Display	Indicates selected Source device.
3	IR Receiver	Control Matrix using Octava remote.
4	Power Input 9v (PoC)	provides power to Octava PoC compatible Zone Receiver (Rx) units
5	Power Input 9v (Matrix)	provides power to Octava Matrix
6	Wired IR input	connect Octava supplied IR Receiver Extension cable
7	IR Output (1-4)	connect Octava supplied IR Transmitter Blaster cable
8	HDMI Input (1-4)	connect High Speed HDMI cables to Source device.
9	HDMI Output (A-D)	connect High Speed HDMI cables to AVR or Display device.
10	Dual RJ-45 Output (A-D) CAT-6	connect Twisted Pair cables (x2) to Octava Zone Receiver (Rx) unit.
11	USB Port	for custom EDID/ code updates
12	RS232 Port	for external control of Matrix via PC or proprietary Control system.
13	EDID DIP Switch(1-6)	set Matrix EDID modes

Infrared Overview:

IR can be Routed from any of the 4 connected Zones back to the Matrix plus connected Source devices.

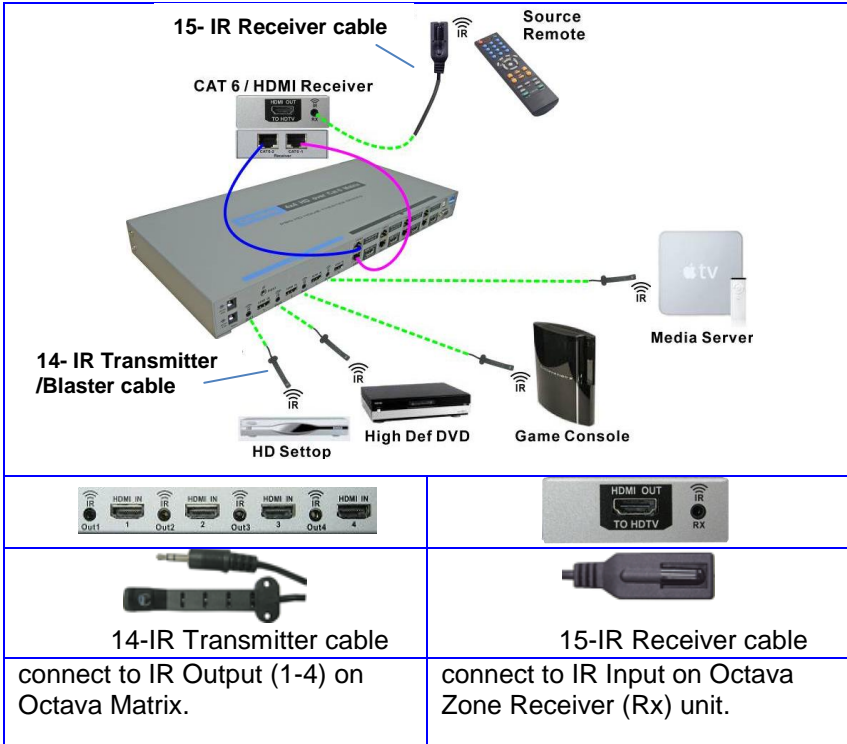

Step	IR Installation
1	Connect an Octava supplied IR Receiver cable to each Zone Rx unit.
2	Connect an Octava supplied IR Blaster cable from the IR Output Port (1-4) on the Octava Matrix and position the Blaster Head over the IR Receiver window on the connected Source device.
3	The Octava Matrix receives IR commands from the Zone Rx unit without the need for an additional IR Blaster cable.





Zone Receiver (RX) Overview:

A Zone Rx unit is positioned close to your Display device and connected to the Octava Matrix via 2xTwisted Pair (CAT5 or CAT6) cables. Connect the Rx unit to your Display device using a short High Speed HDMI cable.

Before you begin your system installation please ensure you identify which type of Octava Rx unit you are working with – PoC, non-PoC. Refer to section: “Identifying Zone Receiver (RX)”

PoC (Power over Cable) Rx units are powered from the Matrix

non-PoC Rx units require a local 5V power supply

	 <p>16-Power Indicator 17- DC Power input for Zone Receiver</p>
 <p>18- CAT 6 Input</p>	 <p>19- HDMI Out to HDTV 20- IR receiver input</p>

	Item	Description
16	Power Indicator	indicates Rx is receiving power
17	DC Input.	ONLY used for non-POC units.-connect local 5v PSU on non-PoC units.
18	RJ-45 Input (1-2).	connect to CAT6 Out (-1 -2) on Zones A-D of Octava Matrix
19	HDMI Out to HDTV	connect to HDTV using High Speed HDMI cable
20	IR receiver	connect Octava supplied IR Receiver cable.



Identifying Zone Receiver (RX)

The Octava matrix features **Power Over Cable (PoC)**. PoC enables the Matrix to power the PoC Zone Receiver units directly, using the PoC power supply.

Before you begin your system installation please ensure you identify which type of Octava Rx unit you are working with – PoC, non-PoC.



PoC Zone Receiver:

The Octava Matrix should include CAT 6 receivers with PoC. (power over cable). Please verify by inspecting the first 6 serial number and confirm it is: **RXH3IR**

PoC Zone Receivers:			
	Serial Number		
PoC ✓	RXH3IRXXXXXX		

NON- PoC Zone Receiver (RX):

If you are upgrading or replacing only the matrix, the Zone Receiver you installed may be older. The Zone Receivers in the following table **do NOT** have PoC. capability.



non PoC			
	Serial Number		
NO PoC ✗	RXH1RXXXXXX		
NO PoC ✗	RXH21RXXXXXX		

If you are unsure or need assistance, please contact us.

Powering the PoC Zone Receiver:



Power Over Cable (PoC) enables the Matrix to power the PoC Zone Receiver units directly, using the PoC power supply.

PoC – Zone Rx is powered via the connected Twisted Pair cables (CAT5 or CAT6) from the PoC power supply connected to the PoC socket on the Matrix.

Matrix PoC Power Port	PoC Zone Receiver
 <p>connect Octava supplied PoC power supply (9V, 4A)</p>	 <p>local power supply not required.</p>

Powering non-PoC Zone Receiver:

non-PoC – Zone Rx is powered by a local 5V PSU connected to the Power Socket on the Rx unit.

Matrix PoC Power Port	non-PoC Zone Receiver
 <p>local power supply not required.</p>	 <p>connect Octava supplied 5V PSU to Rx unit power socket</p>

If you are unsure or need assistance, please contact us.

Ethernet cable recommendations:







Using Shielded, Stranded CAT6 or CAT7 cable will ensure maximum signal integrity plus optimum rejection of external interference.

UTP CAT5 and CAT6 cables can be used with your Octava system though they may result in limiting the maximum attainable distance between the Matrix and the Rx unit when running HD signals.





	Cable Type	Note
1	CAT 7 cable is recommended	Best
2	Shielded CAT 6 cable is recommended	Good
3	UTP CAT 6 cable	For short links 50ft or less.
Use EIA/TIA-568-B standard when terminating your CAT5, CAT6 or CAT7 cables.		

Ethernet cable installation recommendations:

Use your cable suppliers recommended RJ-45 connector/crimp tool with your CAT5, CAT6 or CAT7 cables and ensure you pay particular attention to the quality of the termination on all cables.





DO/Recommend	
	Use shielded CAT 6 or CAT 7 with good RJ-45 terminators
	Use a direct cable connection between the Matrix and Receiver unit.
DO NOT	
	Do Not connect thru Ethernet switches or routers
	For optimum signal integrity avoid passing your signals though any form of Patch-panel, Wall-plate or punch-down terminations
	Do Not connect cables thru extraneous RJ-45 couplers, wall plates.
	Do Not tightly coil /loop the Ethernet cables

Installation:

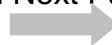
Step		
0	<ul style="list-style-type: none"> • Disconnect ALL cables from the MATRIX / Zone Receivers • Power OFF all HDTV/Displays/Audio Receivers • Power OFF all Video Sources • Power OFF Matrix • Power OFF Zone Receivers 	
1	Verify that the Configuration Switch is set to the factory default mode.	
2	Connect HDMI sources to HDMI IN 1-4	
Connecting Output with HDMI cable		
3	If you are connecting with HDMI cable: Connect HDMI cable to HDMI output A-D and HDTV	 <p style="text-align: center;">HDMI Out</p>
Connecting Output with Ethernet cables		
4	Verify that the Zone Receiver you have supports PoC (See page 7) If the Zone Receiver has PoC proceed to step 5.	IF your Zone Receiver are non PoC proceed to Alternative steps A1-A5. (Skip to page 12)
5	Connect the 9VDC power supply to the DC/9V port labeled PoC. →	

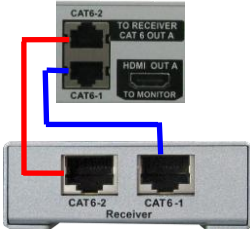





CONTINUE on Next Page

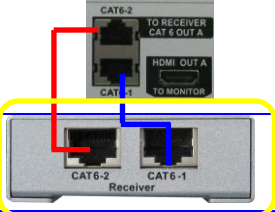

6	<p>Connect <u>CAT6 -1</u> of Matrix and Receiver with CAT 6 cable.</p> <p>Connect <u>CAT6 -2</u> of Matrix and Receiver with CAT 6 cable.</p>	
7	<p>Verify the Power LED Indicator is On.</p> <p><i>If not, please check your connections.</i></p>	 <p><i>Note: the 5V power of Receiver is not used for Matrix powered by P.O.C.</i></p>
8	<p>Connect HDMI output of Receiver to HDTV</p>	 <p>To HDTV</p>
9	<p>Install I.R. receiver cable. Install I.R. transmitter cable</p>	<p>See page 5 “infrared overview”</p>
10	<p>Connect the 9VDC power supply to the DC/9V port labeled Matrix.</p>	
11	<p>Verify the Matrix LED Display turns on and displays 1.</p>	
12	<p>Power ON HDTV Power ON Source Done.</p>	

If you are unsure or need assistance, please contact us.

Alternative Steps A1-A6 are only for installations with non PoC Zone Receivers.

A1	Do <u>Not</u> connect Power to the PoC Power Port	
A2	Connect <u>CAT6 -1</u> of Matrix and Receiver with CAT 6 cable. Connect <u>CAT6 -2</u> of Matrix and Receiver with CAT 6 cable. Non PoC receiver →	
A3	Connect 5 V power to the Zone Receiver Verify the Power LED Indicator is On.	 <p style="text-align: center;">Connect to 5V power supply</p>
A4	Connect HDMI output of Receiver to HDTV	 <p style="text-align: center;">To HDTV</p>
A5	Install I.R. receiver cable. Install I.R. transmitter cable	See page 5 “infrared overview”
A6	Connect the 9VDC power supply to the DC/9V port labeled Matrix. 	
A7	Verify the Matrix LED Display turns on and displays 1.	
A8	Power ON HDTV Power On Source Done.	

If you are unsure or need assistance, please contact us.

Front Panel Control:

Directly press the select buttons to change inputs.
For example:

To set Output A to Input 2. Simply press the A button until the LED displays 2.



Remote Control Guide:

Turns On/Off the
HDMI Matrix

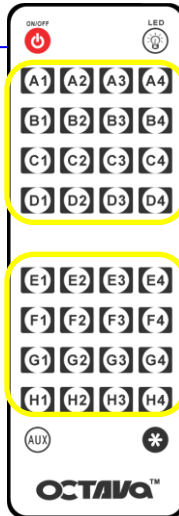

Turns on/off the Front
LED Display

Input Select

Example:
Press C3-changes
Output C to Input3

Not used for
HD44CATMX

EDID Switch:

The EDID switch is used to program the Matrix into various EDID modes.

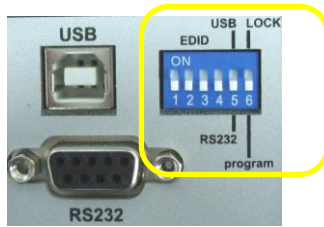

Switch Number	1	2	3	4	5	6
Name	EDID switch	EDID switch	EDID switch	EDID switch	USB / RS232	Program/LOCK switch
Function	EDID MODE select	EDID MODE select	EDID MODE select	EDID MODE select	USB / RS232 select	Program/LOCK switch
						Down= Program mode Up= Locked

USB Service Port:

The USB port is for service and EDID updates if needed.
Contact us for this feature.

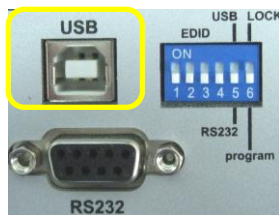





EDID Configuration:

The Octava Matrix can be configured to 5 EDID settings.
It is recommended to keep the EDID in the default factory mode 1.





*Custom EDID mode can be downloaded via USB. Contact us for this feature.

To change the EDID settings, please see section “*changing EDID settings*” for programming instructions.

Mode	Video	Audio	Description	Switch settings
1	480P,720 I/P, 1080 I/P	2 CH PCM, Bitstream (Dolby Digital, DTS)	Default Mode. [Internal EDID]	
2	Read EDID of all monitors/receivers and set: Video=Minimum Resolution of devices connected.	Read EDID of all monitors/receivers and set: AUDIO =Maximum capability of devices connected.	[External EDID]	
3	480P,720 I/P, 1080 I	2 CH PCM	Basic Mode. [Internal EDID]	
4	480P, 720 I/P, 1080 I/P, + 3D specifier	2 Ch PCM, Bitstream (Dolby Digital, DTS)	3D Mode. [Internal EDID]	
5	480P,720 I/P, 1080 I/P	2 CH PCM	[Internal EDID] *Custom Mode	

Changing EDID mode:





It is recommended to keep the EDID in the factory default MODE1. If necessary, you may set to different EDID mode by following these instructions.

Step	Action		Notes
1	Disconnect all sources and display from Matrix		
2	Set switch 1,2,3,4,5,6 to down position as shown		
3	Set the EDID to the mode desired. (MODE 2 shown.)	See page 15 “EDID Configuration” for other EDID modes	
4	Reset Power to the Matrix by disconnecting the power and reconnecting power.		
5	The LED will now indicate the EDID Mode that you will program.(mode 2 shown)	1= mode 1 2= mode 2 3= mode 3 4= mode 4 5= mode 5	

If you are unsure or need assistance, please contact us.

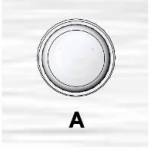
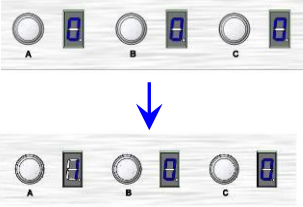
CONTINUE on Next Page



6	<p>Press the A button on the front panel. LED will count from 000 to 100 while programming.</p>  <p style="text-align: center;">A</p>	<p>LED will count from 000 to 100 while programming.</p>	
7	<p>Wait. Programming is complete when LED indicates "1"</p>		
8	<p>Set to LOCK Position</p>		
9	<p>Connect all video sources and displays and turn ON</p>		
10	<p>Reset Power to the Matrix by disconnecting the power and reconnecting power.</p>		

If you are unsure or need assistance, please contact us.

RS-232 Control Commands

The Matrix can be easily integrated with 3rd Party control systems via RS232 control. The following shows the control protocol for controlling the Matrix.

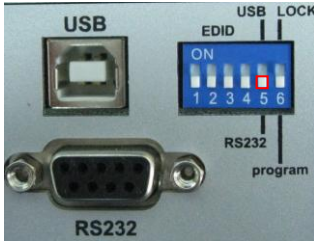

Set the switch to RS-232 side as shown.

RS-232 protocol	
Baud Rate	9600
Data Bits	8
Parity Check	none
Stop Bits	1
Flow control	none

Controlling the Matrix via RS232 can be done by send a series of commands per the RS232 Command Table

Basic controls					
Note: The commands are in HEX. No spaces between HEX codes. "0x" denotes HEX. No need to enter "0x"					
	HEX CODE				
Port Status	0x02	0x30	0x30	0x31	0x03
Turn ON LED	0x02	0x30	0x30	0x33	0x03
Turn OFF LED	0x02	0x30	0x30	0x34	0x03
Turn ON Power	0x02	0x30	0x30	0x35	0x03
Turn OFF Power	0x02	0x30	0x30	0x36	0x03

Example:

To turn off LED , send Command:

02 30 30 34 03 in Hex

Switching Commands

Note: The commands are in HEX. No spaces between HEX codes.
 "0x" denotes HEX. No need to enter "0x"

Output A Switching Commands	HEX CODE				
Select OUT A to Input port 1	0x02	0x32	0x31	0x31	0x03
Select OUT A to Input port 2	0x02	0x32	0x31	0x32	0x03
Select OUT A to Input port 3	0x02	0x32	0x31	0x33	0x03
Select OUT A to Input port 4	0x02	0x32	0x31	0x34	0x03
Output B Switching Commands					
Select OUT B to Input port 1	0x02	0x32	0x32	0x31	0x03
Select OUT B to Input port 2	0x02	0x32	0x32	0x32	0x03
Select OUT B to Input port 3	0x02	0x32	0x32	0x33	0x03
Select OUT B to Input port 4	0x02	0x32	0x32	0x34	0x03
Output C Switching Commands					
Select OUT C to Input port 1	0x02	0x32	0x33	0x31	0x03
Select OUT C to Input port 2	0x02	0x32	0x33	0x32	0x03
Select OUT C to Input port 3	0x02	0x32	0x33	0x33	0x03
Select OUT C to Input port 4	0x02	0x32	0x33	0x34	0x03
Output D Switching Commands					
Select OUT D to Input port 1	0x02	0x32	0x34	0x31	0x03
Select OUT D to Input port 2	0x02	0x32	0x34	0x32	0x03
Select OUT D to Input port 3	0x02	0x32	0x34	0x33	0x03
Select OUT D to Input port 4	0x02	0x32	0x34	0x34	0x03

1 RU Rackmount :

The Matrix can be installed in a 1 RU rack by simply installing the rack mounts included.



Disabling /Enabling IR Remote Receiver:

To disable the front panel IR remote receiver-insert the plastic plug into the IR jack as shown.



IR receiver -disabled



IR receiver -enabled

Warranty

Octava warrants the equipment purchased to be free from defects in material and workmanship under normal use and service for a period of 1 year. In the event applicable law imposes any implied warranties, the implied warranty period is limited to 1 year from the date of receipt. If Octava's equipment fails because of defects (1) year from the date of receipt, Octava will at its option, A) repair or replace the equipment, or B) request return of equipment for refund of the price paid for the product provided that the equipment has not been subjected to mechanical, electrical or other abuse or modifications. Proof of sale required to claim warranty.

Disclaimers

IN NO EVENT SHALL OCTAVA'S OR ITS SUPPLIER'S LIABILITY FOR ANY CLAIM WHATSOEVER EXCEED THE COST OF THE PRODUCTS GIVING RISE TO THE CLAIM, WHETHER BASED IN CONTRACT, WARRANTY, INDEMNITY OR TORT (INCLUDING, WITHOUT LIMITATION, NEGLIGENCE AND STRICT LIABILITY) OR OTHERWISE. IN NO EVENT SHALL OCTAVA INC. OR ITS SUPPLIERS BE LIABLE FOR ANY SPECIAL, INCIDENTAL, CONSEQUENTIAL OR OTHER INDIRECT DAMAGES (INCLUDING, WITHOUT LIMITATION, LOSS OF REVENUES, PROFITS OR OPPORTUNITIES), HOWEVER CAUSED, ON ANY THEORY OF LIABILITY, WHETHER OR NOT OCTAVA INC HAS BEEN ADVISED OF THE POSSIBILITY OF SUCH DAMAGES.

WHILE EVERY PRECAUTION HAS BEEN TAKEN IN THE PREPARATION OF THIS MANUAL, OCTAVA ASSUMES NO RESPONSIBILITY FOR ERRORS OR OMISSIONS. IN NO EVENT WILL OCTAVA ASSUME ANY LIABILITY FOR DAMAGES RESULTING FROM THE USE OF THE INFORMATION CONTAINED HEREIN. OCTAVA RESERVES THE RIGHT TO CHANGE THE SPECIFICATIONS, FUNCTIONS OR CIRCUITRY OF THE PRODUCT WITHOUT NOTICE.

Description	Specifications
Model	HD44CATMX
HDMI Inputs	4
HDMI Outputs	4
RJ-45 CAT Dual output	4
IN/Out Connectors	19 pin HDMI female type-A
RS-232 control port	1
Display Selection	Remote, Manual, RS-232
Video Resolution	480 P, 720 I/P, 1080 I/P
Video Data Rate	6.75 Gbps
Vertical Frequency Scan Rate	24 / 50 / 60 Hz
Dimension	16.85 x 8.04 x 1.67 inch (427.9x 204.3 x 42.3 mm)
DC adapter (included)	9VDC, 4A (x2)
Rackmount capable	1RU, Rack mounts included
Remote control (IR)	Infrared, Discrete code

For Questions and support:

Email : info@octavainc.com

URL: www.octavainc.com

Copyright© 2011 Octava Inc. All rights reserved.

HDMI, the HDMI logo and High-Definition Multimedia Interface are trademarks or registered trademarks of HDMI Licensing LL.C

All trademarks are the sole property of their respective companies

Rev.E